



SPECIFICATION SHEET

Model #:	_____	Qty:	_____
Project #:	_____		
Consultant:	_____		

QUALITY FOOD SERVICE EQUIPMENT

PREMIUM SINKS



DIMENSIONS

2 bowls

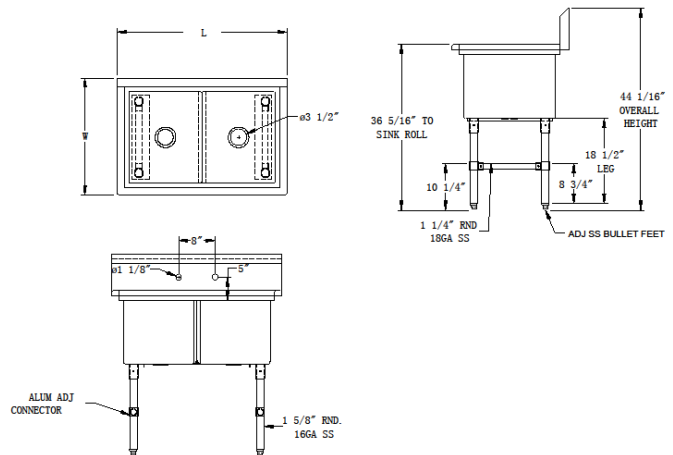

MATERIAL

- ◆ 16GA 300 stainless steel fabricated
- ◆ Stainless steel legs & gussets
- ◆ Stainless steel cross bracing
- ◆ Stainless steel bullet feet

FEATURES

- ◆ 10"H backsplash with 2" return to wall
- ◆ 8" on center splash mount faucet holes
- ◆ 3-1/2" die-stamped drain opening
- ◆ Cross bracing for reinforced support
- ◆ Adjustable bullet feet

Model#	Bowl Size LxWxH	Length	Width
2SS-162014	16" X 20" X 14"	37-1/8"	25-1/2"
2SS-181814	18" X 18" X 14"	41-1/8"	23-1/2"
2SS-182414	18" X 24" X 14"	41-1/8"	29-1/2"
2SS-242414	24" X 24" X 14"	53-1/8"	29-1/2"